



INSTALL GUIDE

2016 KIA SORENTO PTS SUV AUTOMATIC



DOCUMENT NUMBER

A971A9

REVISION DATE

20200122_160450

FIRMWARE

RSA-HK11A

HARDWARE

CMHCXA0

ACCESSORIES

ATTENTION: TO COMPLETE THIS INSTALLATION SOME ACCESSORIES MAY BE REQUIRED. VISIT OUR WEBSITE TO SEE ALL THE REQUIRED ACCESSORIES FOR YOUR VEHICLE.

TERMS OF USE

Automotive Data Solutions Inc. ("ADS") products are strictly intended for installation by Certified Technicians who are employed by a registered business specialized in the installation of automotive aftermarket electronics products. Prior to beginning installation of an ADS product in a vehicle, it is the Certified Technician's responsibility to review the most current Product Guide, Install Guide and vehicle-specific notes available in Weblink®. ADS is not responsible for any damages whatsoever, including but not limited to any consequential damages, incidental damages, damages for loss of time, loss of earnings, loss of profit, commercial loss, loss of economic opportunity and the like that may or may not have resulted from the use, misuse, improper installation or operation of its products. ADS reserves itself the right to suspend any Weblink® account without notice and decline to offer technical support to non-Certified Technicians, noncompliant Certified Technicians or end users.

IMPORTANT

A SECURITY PLATE MAY NEED TO BE REMOVED TO ACCESS SMART KEY MODULE CONNECTORS.

USE A BOLT EXTRACTOR AND A RATCHET TO REMOVE THE PLATE'S TAMPER PROOF SCREWS.

USE INCLUDED BOLTS TO REINSTALL SECURITY PLATE IF NECESSARY.

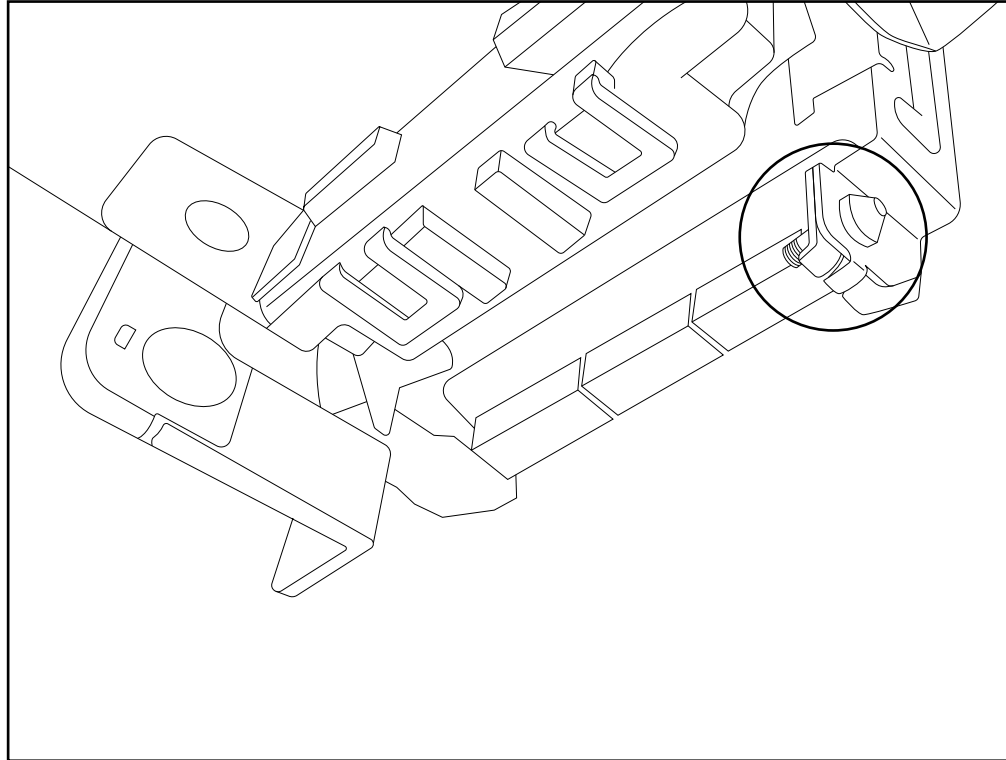

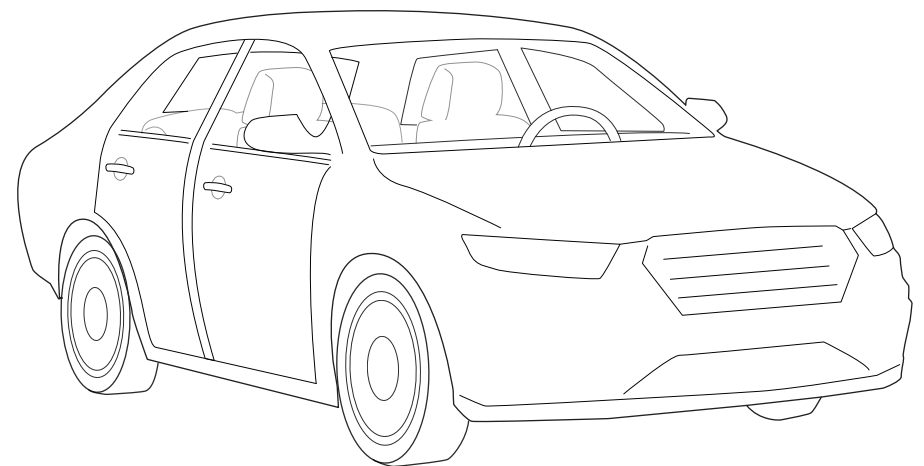
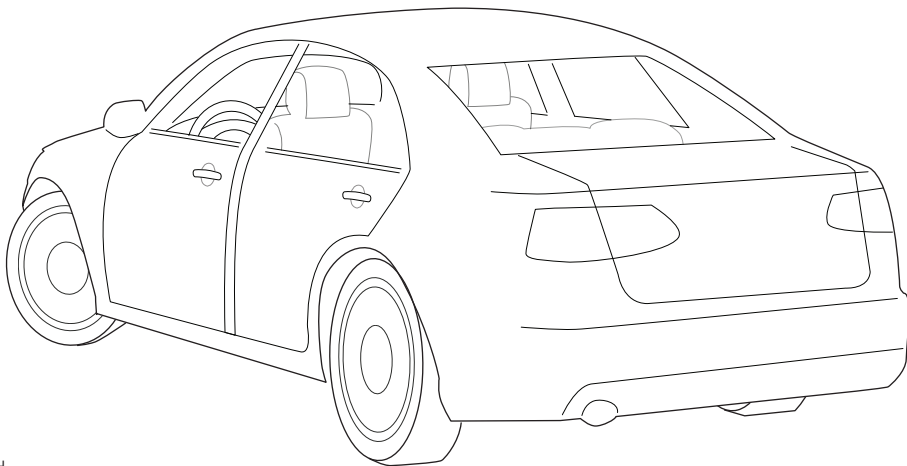
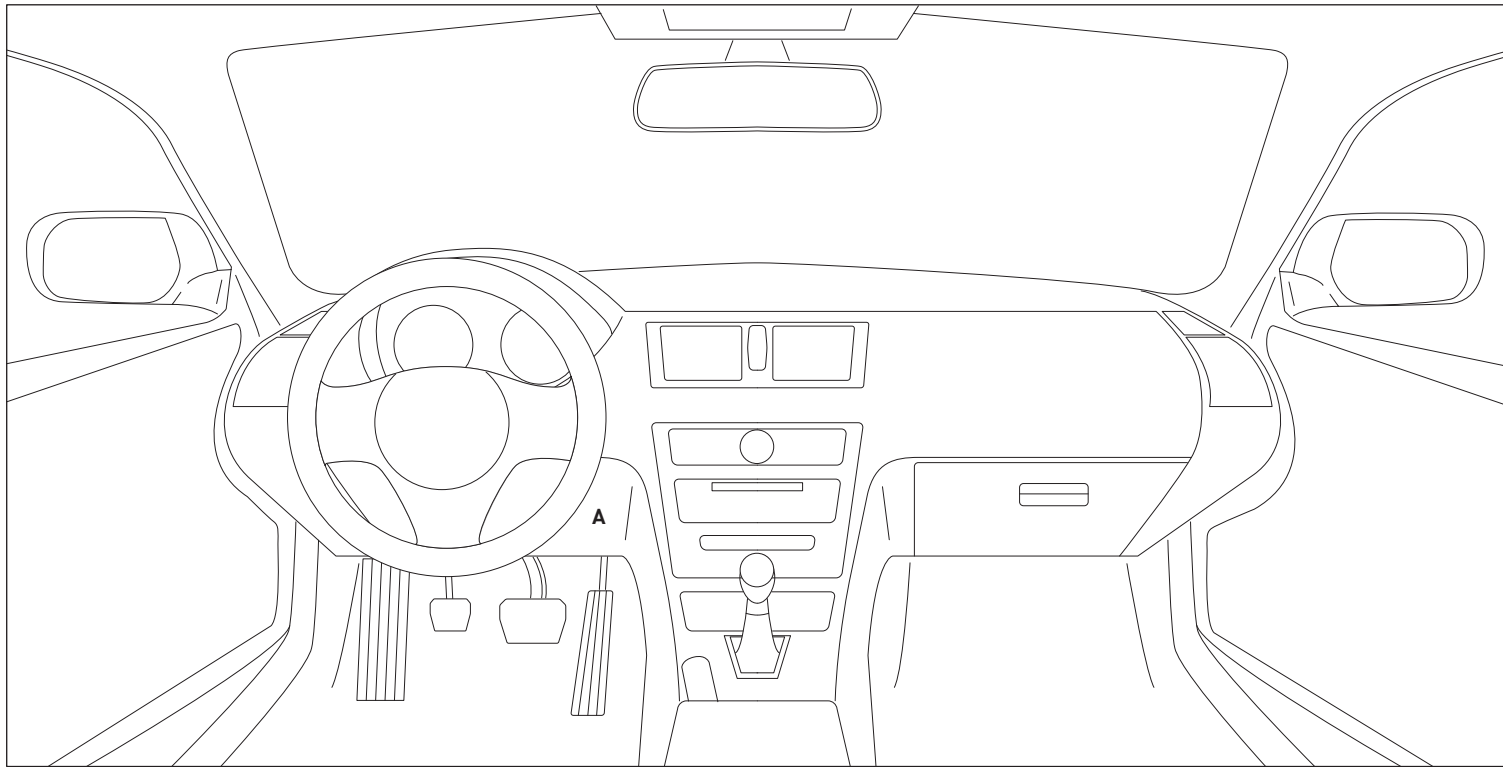

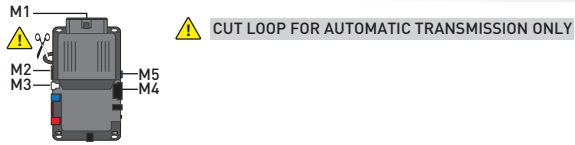

A SECURITY PLATE MAY NEED TO BE REMOVED TO ACCESS SMART KEY MODULE CONNECTORS. REFER TO TECHNICAL NOTE.

SMART KEY MODULE, ABOVE GAS PEDAL (A)

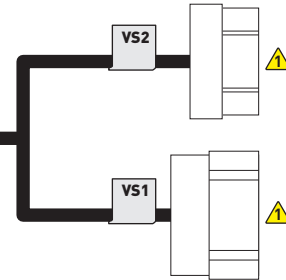
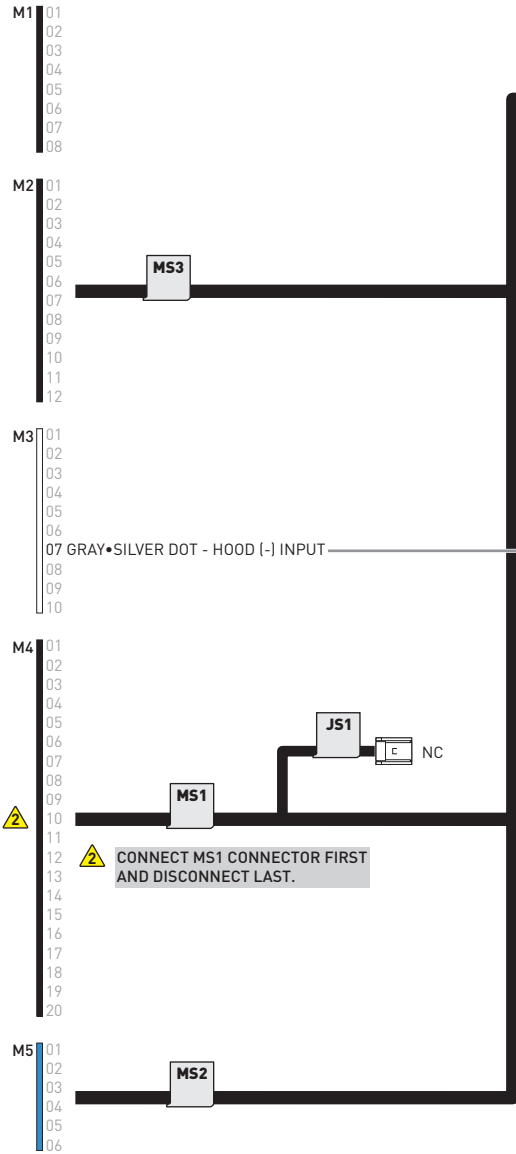

1: WHITE 26 PIN SMART KEY MODULE CONNECTOR

1: SMART KEY MODULE HARNESS

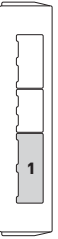

CONNECT MS1 CONNECTOR FIRST AND DISCONNECT LAST.

INSTALL THE SUPPLIED HOOD SWITCH IF THE VEHICLE IS NOT EQUIPPED WITH ONE.

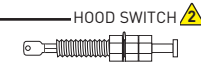

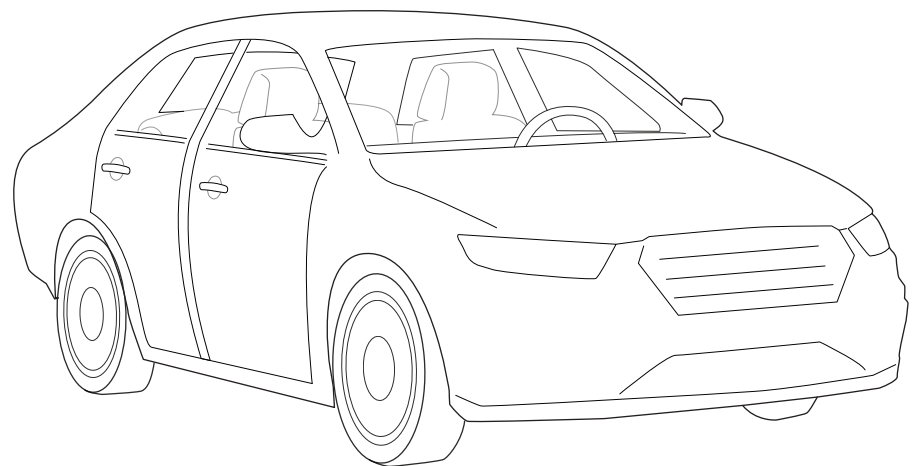
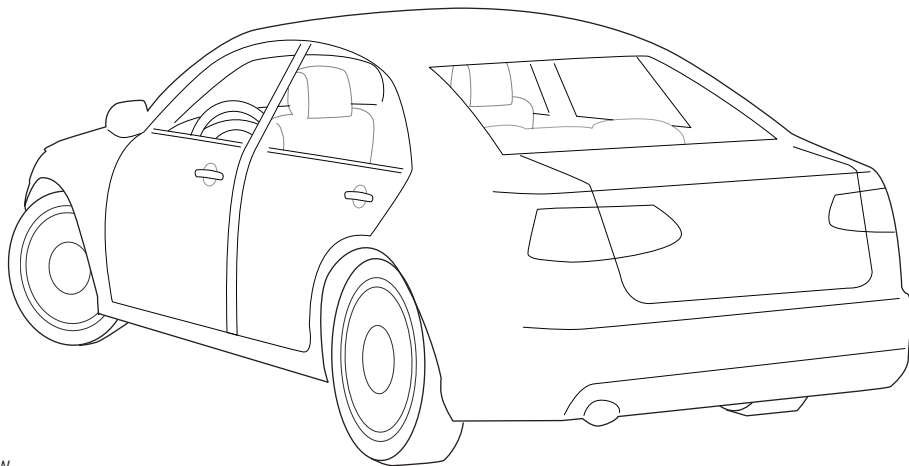
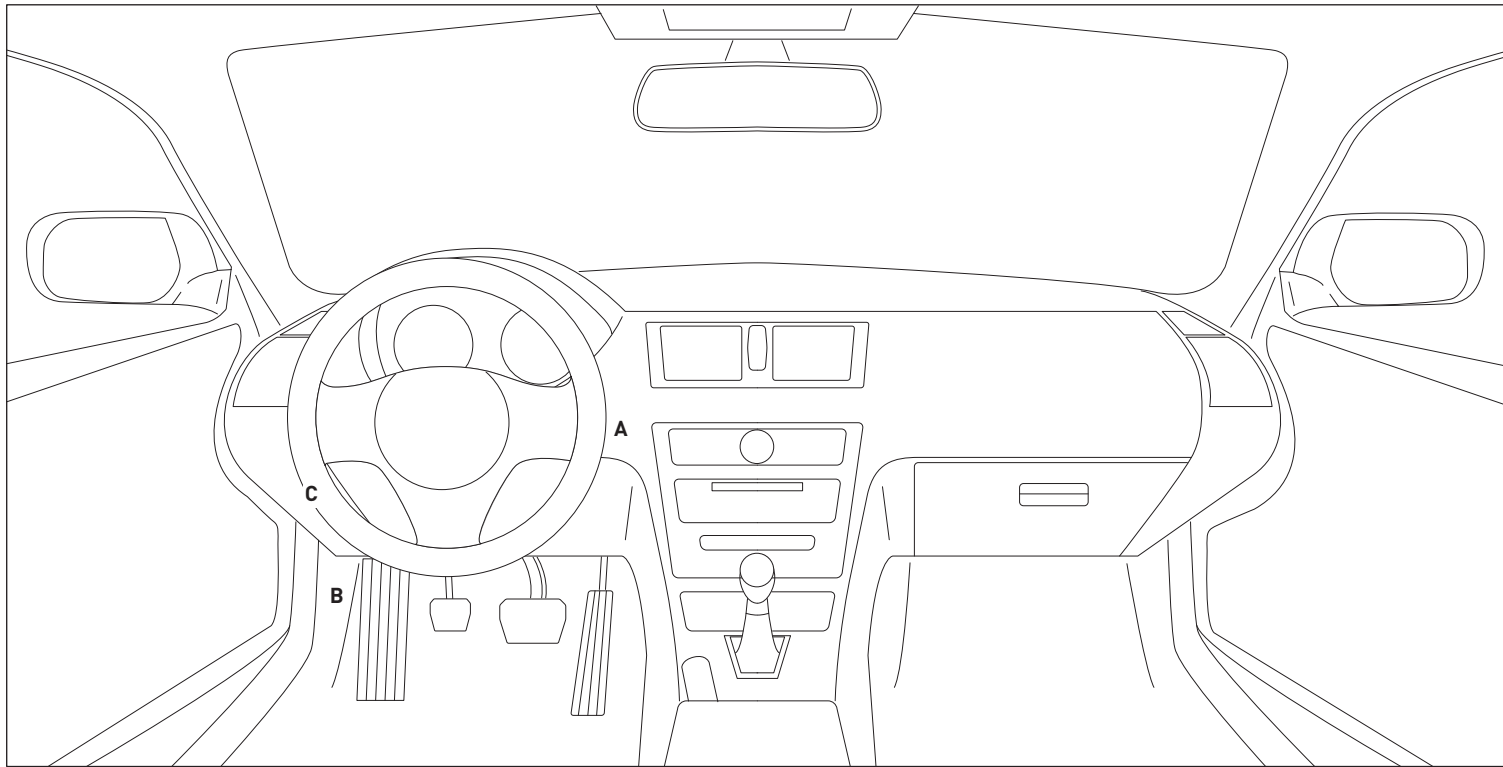

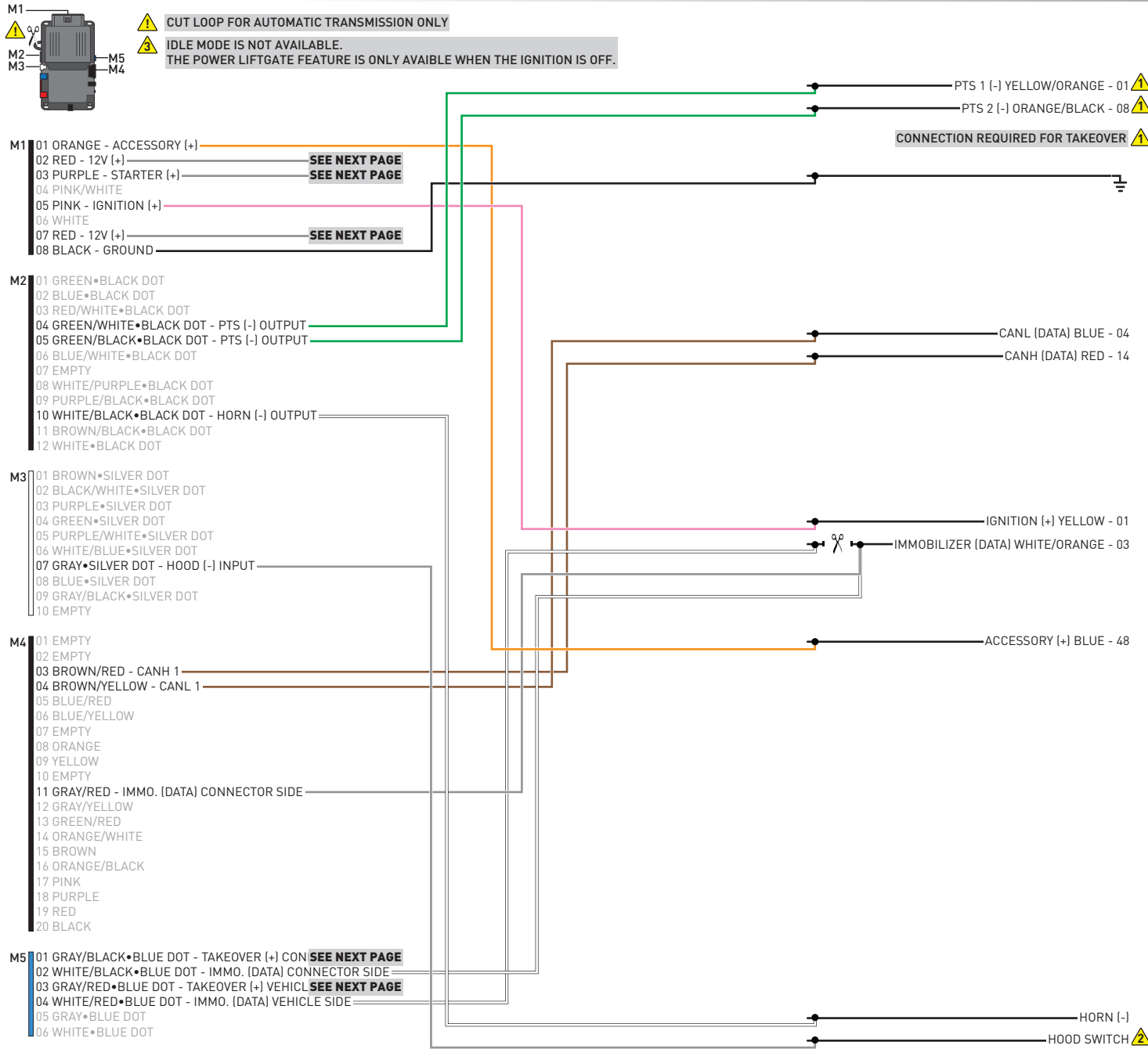

⚠ CUT LOOP FOR AUTOMATIC TRANSMISSION ONLY

⚠ IDLE MODE IS NOT AVAILABLE. THE POWER LIFTGATE FEATURE IS ONLY AVAILABLE WHEN THE IGNITION IS OFF.

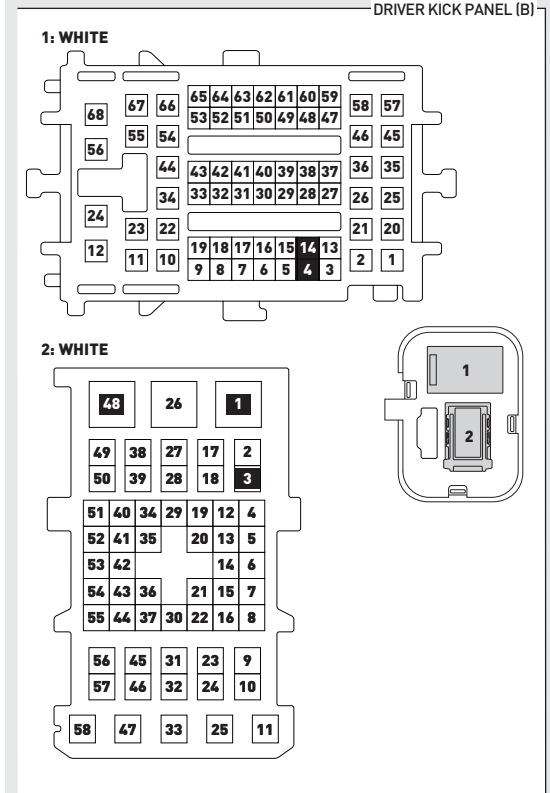
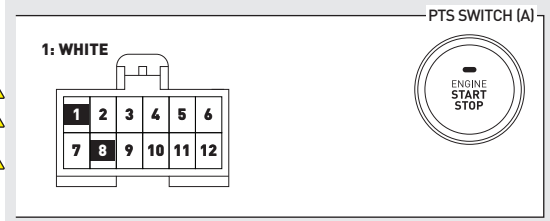

INSTALL THE SUPPLIED HOOD SWITCH IF THE VEHICLE IS NOT EQUIPPED WITH ONE. **⚠**

MORE ON NEXT PAGE ▼

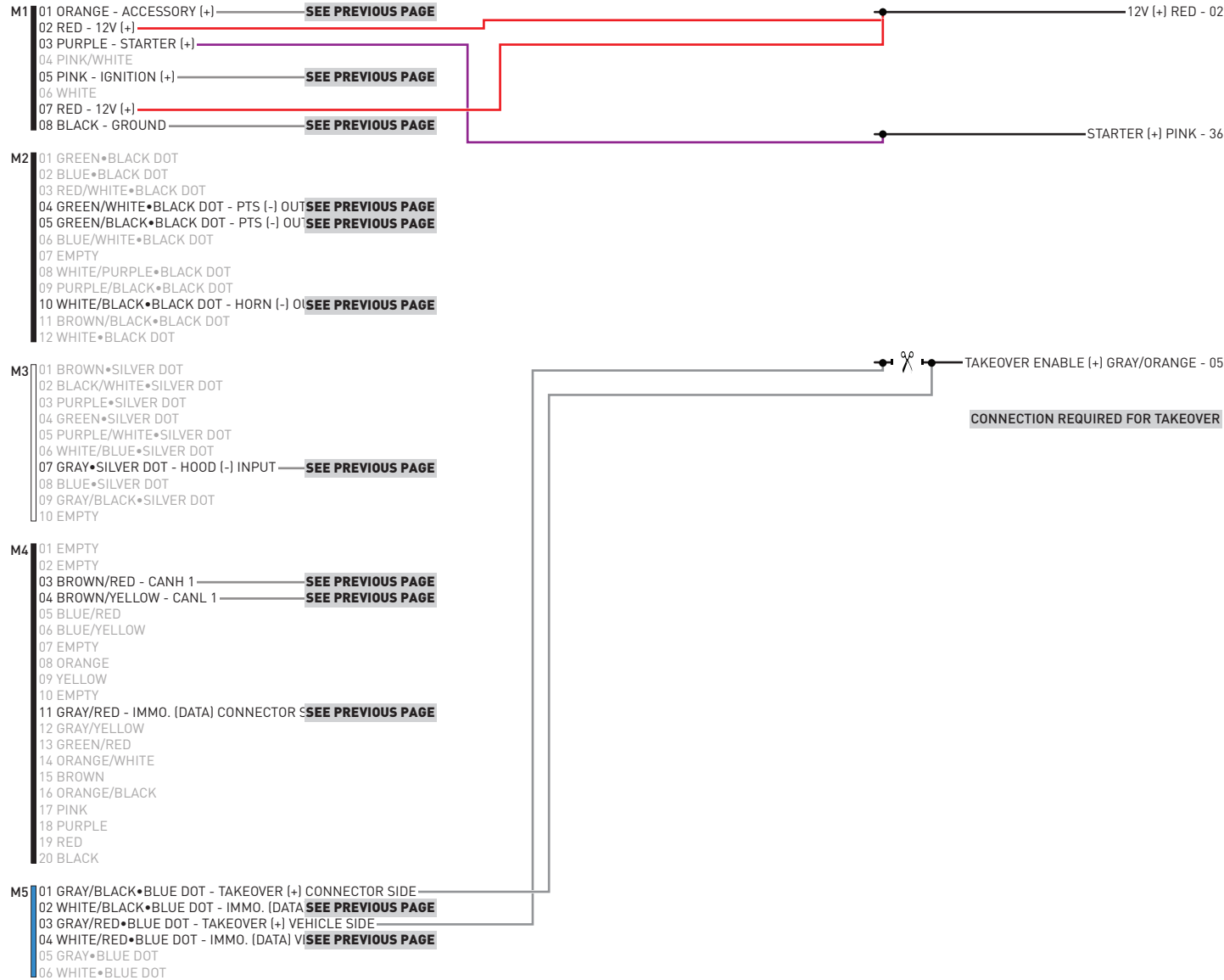
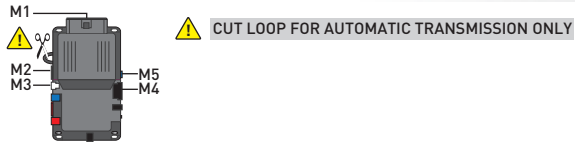

MORE ON PREVIOUS PAGE

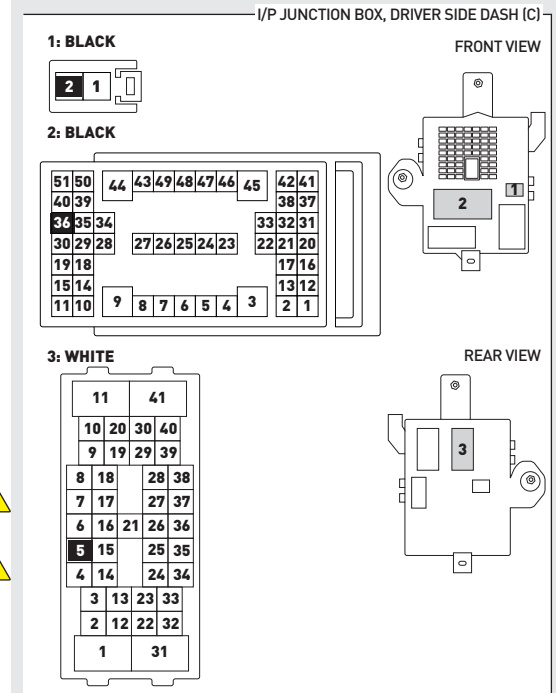

>>



WARNING: All vehicle doors must be closed and locked prior to remote start sequence. When programming, only one key fob will be used. The other one must be located at least 10 feet away from the vehicle.

01



Set ignition to ON position.

02



Wait, LED 1 will turn solid GREEN for 2 seconds.

03



Set ignition to OFF position.

04



START vehicle for 15 seconds.

05



Press and hold the brake pedal.

06



Press and release the module's programming button.

07



Release the brake pedal.

08



Wait, LED 2 will flash GREEN.

09



Module Programming Procedure completed.

>>



All vehicle doors must be closed and locked prior to remote start sequence.

01



Time restriction. Complete steps 2 to 5 within 45 seconds.

02



Press unlock on OEM or aftermarket remote or request switch.

03



Open driver door and enter vehicle.

04



Close driver door.

05



Press and release BRAKE pedal.

06



Take over procedure completed.

>>



Failure to follow procedure will result in vehicle engine shutdown.

CHECKLIST - WITH AFTERMARKET KEYFOB

| | | | |
|--------------------------|--|--------------------------|--|
| 1 | WARNING: Vehicle engine will start many times. Test in a well ventilated area. | 9 | Press the START/STOP button once [1x] on the aftermarket keyfob to shut down vehicle. |
| 2 | Close all vehicle doors, hood and trunk. | | Question 7: Does the vehicle shut down? |
| 3 | Press the LOCK button once [1x] on the aftermarket keyfob. | <input type="checkbox"/> | YES: Go to next step. |
| | Question 1: Do the doors lock? | <input type="checkbox"/> | NO: Repeat step. If problem persists, press the brake pedal once [1x] to shut down the vehicle and call technical support. |
| <input type="checkbox"/> | YES: Go to next step. | 10 | RAP and auto light shutdown test |
| <input type="checkbox"/> | NO: Verify the remote programming, the RF connections and the wired door lock/unlock connections as illustrated in the wiring diagram, if applicable. Repeat the test and call technical support, if the problem persists. | | Question 8: Did the radio, interior controls and headlights turn off within 60 seconds after remote start shutdown? |
| 4 | Press the UNLOCK button once [1x] on the aftermarket keyfob. | <input type="checkbox"/> | YES: Go to next step. |
| | Question 2: Do the doors unlock? | <input type="checkbox"/> | NO: Verify the RAP SHUTDOWN connections as illustrated in the wiring diagram. Repeat the test and call technical support if the problem persists. |
| <input type="checkbox"/> | YES: Go to next step. | 11 | Open hood. |
| <input type="checkbox"/> | NO: Verify the remote programming, the RF connections and the wired door lock/unlock connections as illustrated in the wiring diagram, if applicable. Repeat the test and call technical support, if the problem persists. | 12 | If not already installed, affix the mandatory orange warning sticker under the hood and proceed to next step. |
| 5 | Press the TRUNK release button once [1x] on the aftermarket keyfob if supported. | 13 | Press the START/STOP button once [1x] on the aftermarket keyfob to remote start vehicle. |
| | Question 3: Does the trunk or hatch open/unlock? | | Question 9: Does the vehicle remote start? |
| <input type="checkbox"/> | YES: Close trunk or hatch and go to next step. | <input type="checkbox"/> | YES: The vehicle is not equipped with a factory hood pin. Install a mandatory aftermarket hood switch, then repeat the test. |
| <input type="checkbox"/> | NO: Verify the remote programming, the RF connections and the wired trunk/hatch connections as illustrated in the wiring diagram, if applicable. Repeat the test and call technical support, if the problem persists. | <input type="checkbox"/> | NO: Go to next step. |
| 6 | Press the AUX 1 button once [1x] on the aftermarket keyfob if supported. | 14 | Close hood. |
| | Question 4: Does the driver side sliding door open? | 15 | Enter vehicle and close the doors. |
| <input type="checkbox"/> | YES: Press the AUX 1 button once [1x] to close the driver sliding door and go to next step. | 16 | Press the START/STOP button once [1x] on the aftermarket keyfob to remote start vehicle. |
| <input type="checkbox"/> | NO: Verify the remote programming and the RF connections. Repeat the test and call technical support, if the problem persists. | 17 | Wait for the vehicle to start. |
| 7 | Press the AUX 2 button once [1x] on the aftermarket keyfob if supported. | 18 | Press brake pedal. |
| | Question 5: Does the passenger side sliding door open? | | Question 10: Does the vehicle shut down? |
| <input type="checkbox"/> | YES: Press the AUX 2 button once [1x] to close the passenger sliding door and go to next step. | <input type="checkbox"/> | YES: Go to next step. |
| <input type="checkbox"/> | NO: Verify the remote programming and the RF connections. Repeat the test and call technical support, if the problem persists. | <input type="checkbox"/> | NO: The module does NOT detect the brake pedal signal. Press the START/STOP button once [1x] on the aftermarket keyfob to shut down vehicle, check connection as illustrated in the wiring diagram, if applicable, and call technical support. |
| 8 | Press the START/STOP button once [1x] on the aftermarket keyfob to remote start vehicle. | 19 | Exit vehicle. |
| | Question 6: Does the vehicle remote start? | 20 | Installation checklist completed. |
| <input type="checkbox"/> | YES: Go to next step. | | |
| <input type="checkbox"/> | NO: Verify the remote programming, the RF connections and check the remote start error codes. Repeat the test and call technical support, if the problem persists. | | |

CHECKLIST - WITH OEM KEYFOB

| | |
|--------------------------|---|
| 1 | WARNING: Vehicle engine will start many times. Test in a well ventilated area. |
| 2 | Close all vehicle doors, hood and trunk. |
| 3 | Press LOCK button three times [3x] rapidly on the OEM keyfob to remote start vehicle. |
| | Question 1: Does the vehicle remote start? |
| <input type="checkbox"/> | YES: Go to next step. |
| <input type="checkbox"/> | NO: The module doesn't detect OEM remote lock button from the vehicle communication network. Check all connections, repeat the test and call technical support, if the problem persists. |
| 4 | Press LOCK button three times [3x] rapidly on the OEM keyfob to shut down vehicle. |
| | Question 2: Does the vehicle shut down? |
| <input type="checkbox"/> | YES: Go to next step. |
| <input type="checkbox"/> | NO: Repeat step. If the problem persists, press on the brake pedal once [1x] to shut down the vehicle and call technical support. |
| 5 | RAP Shutdown test |
| | Question 3: Did the radio, interior controls, and headlights turn off within 60 seconds after remote start shutdown? |
| <input type="checkbox"/> | YES: Go to next step. |
| <input type="checkbox"/> | NO: Verify the RAP SHUTDOWN connections as illustrated in the wiring diagram. Repeat the test and call technical support, if the problem persists. |
| 6 | Open hood. |
| 7 | If not already installed, affix the mandatory orange warning sticker under the hood and proceed to next step. |
| 8 | Press LOCK button three times [3x] rapidly on the OEM keyfob to remote start vehicle. |
| | Question 4: Does the vehicle remote start? |
| <input type="checkbox"/> | YES: The vehicle is not equipped with a factory hood pin. Install a mandatory aftermarket hood switch, then repeat the test. |
| <input type="checkbox"/> | NO: Go to next step. |
| 9 | Close hood. |
| 10 | Enter vehicle and close the doors. |
| 11 | Press LOCK button three times [3x] rapidly on the OEM keyfob to remote start vehicle. |
| 12 | Wait for the vehicle to start. |
| 13 | Press brake pedal. |
| | Question 5: Does the vehicle shut down? |
| <input type="checkbox"/> | YES: Go to next step. |
| <input type="checkbox"/> | NO: The module does NOT detect the brake pedal signal. Press LOCK button three times [3x] rapidly on the OEM keyfob to shut down, check the brake connection as illustrated in the wiring diagram, if applicable, and call technical support. |
| 14 | Exit vehicle. |
| 15 | Installation checklist completed. |